

Pneumatic Control Valve with safety function Type 3241-1 and Type 3241-7

Typetested

Application

Control valves for water and steam; with safety function against excess temperature or pressure in heating systems.

Nominal sizes	DN 15 to DN 150
Nominal pressure	PN 16 to PN 40
Temperatures	Water and steam up to 350 °C



The typetested control valve consists of a Type 3241 Globe Valve with:

- Type 3271 Pneumatic Actuator and a solenoid valve (Type 3241-1 Control Valve)
- Type 3277 Pneumatic Actuator and a solenoid valve (Type 3241-7 Control Valve)

Valve body manufactured of:

- Cast iron
- Spheroidal graphite iron
- Cast steel or cast stainless steel
- Forged steel or forged stainless steel

Undivided valve bonnet

Valve plug with metal sealing

The control valves are used for temperature control when connected to a pneumatic or electric controller. Within the safety circuits, the valve also assumes the function of a shut-off device, which is triggered by the signal of a temperature or pressure limitation device and upon air supply failure.

This control valves have been typetested by the German Technical Inspectorate TÜV in accordance with DIN EN 14597, which defines them as a shut-off and control device. The standard version is suitable for water and steam up to 220 °C and, when fitted with an extension bonnet up to 350 °C at operating pressures listed in Technical data (Table 1) and at a maximum permissible ambient temperature of 50 °C. In safety circuits, a strainer (e.g. Type 2 NI according to Data Sheet T 1015 EN) must be installed in the direction of flow upstream of the control valve.

The modular design of the control valves allows them to be equipped with various accessories:

Positioners, limit switches according to IEC 60534-6 and NAMUR recommendation. See Information Sheet T 8350 EN for details.

Versions

Standard version for temperatures from -10 to 220 °C with a pneumatic actuator and either a Type 3701, Type 3963 or Type 449 Solenoid Valve

- **Type 3241-1** (Fig. 1) · Valve with Type 3271 Pneumatic Actuator (see T 8310-1 EN)
- **Type 3241-7** · Valve with Type 3277 Pneumatic Actuator for integral positioner attachment (see T 8310-1 EN)



Fig. 1 · Typetested Type 3241-1 Pneumatic Control Valve with Type 3701 Solenoid Valve

Additional versions with:

- **Flow divider** · For noise reduction, see T 8081 EN
- **Extension bonnet** · For medium temperatures up to 350 °C
- **Balanced valve plug with PTFE ring** · See Table 3b

Also available:

- **Electric control valve with safety function** · See T 5871 EN
- **DIN/DVGW-tested version for gas** · See T 8020 EN
- **Typetested versions** for liquid fuels and liquefied petroleum gas in the liquid phase · See T 8022 EN

Principle of operation (Figs. 2 and 3)

In control operation, the signal pressure p_{st} controlled either by a temperature controller or positioner is applied to the actuator. If the power fails or the safety limiting device interrupts the control current when the set temperature or pressure limits are exceeded, the solenoid valve switches back to the neutral position. As a result, the supply pressure line is shut off, the actuator is vented, and the opposing force of the actuator springs closes the valve.

Register number

The Type 3241 Globe Valves have been typetested by the German Technical Inspectorate TÜV in combination with the Type 3271 and Type 3277 Pneumatic Actuators (register number available on request).

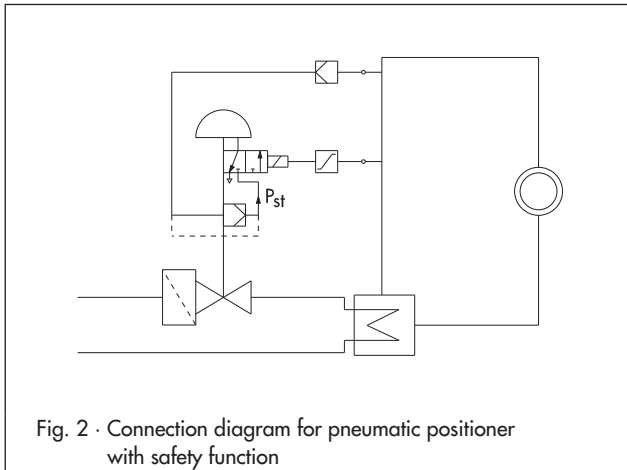

Fig. 2 · Connection diagram for pneumatic positioner with safety function

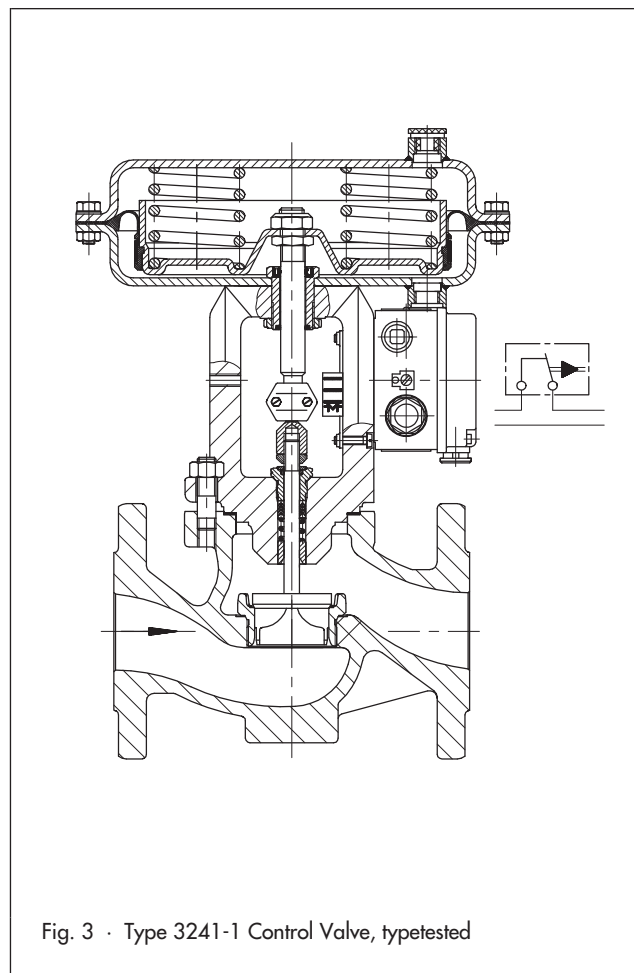

Fig. 3 · Type 3241-1 Control Valve, typetested

Table 1 · Technical data · Refer to Data Sheet T 8015 EN for further technical data

Nominal size		DN 15 to 150					
Material		Cast iron ¹⁾ EN-JL1040/ A 126 B	Spheroidal graphite iron EN-JS1049/ A 395	Cast steel 1.0619/ A 216 WCC	Forged steel 1.0460/ A 105	Cast stainless steel 1.4581	Forged stainless steel 1.4571
Nominal pressure	PN	16	16 · 25	16 · 40		40	40
Differential pressure Δp		Refer to Table 3 for permissible differential pressures					
End connections		Flanges and welding ends according to DIN and ANSI					
Seat/plug sealing		Metal sealing					
Characteristics		Equal percentage · Linear · Quick-opening					
Closing time		< 5 seconds with limiting function					
Maximum medium temperature in °C · Permissible operating pressures acc. to pressure-temperature diagrams (refer to T 8000-2 EN)							
Body without extension bonnet		220 °C · Applies to pressure balancing with PTFE ring					
Body with extension bonnet		300 °C	350 °C	350 °C	350 °C	350 °C	350 °C
Leakage rate acc. to DIN EN 60534-4		Class IV					

¹⁾ With hot water only up to DN 50; in plants conforming to TRD (German technical rules for steam boilers): max. perm. operating pressure 10 bar; in plants conforming to TRB (German technical rules for pressure vessels) up to PN 16 permissible.

Solenoid valve	Type 3701		Type 3963	
Type of protection	–	Intrinsically safe ⊗ II 2 G EEx ia IIC T6 Non-sparking ⊗ II 3 G EEx nA II T6	–	Intrinsically safe ⊗ II 2 G EEx ia IIC T6 Non-sparking ⊗ II 3 G EEx nA II T6
Power supply and power consumption	24 V/50 Hz 230 V/50 Hz both 150 mW	7.5 V DC - 20 mW 24 V DC - 150 mW	24 V/50 Hz 230 V/50 Hz both 150 mW	7.5 V DC - 20 mW 24 V DC - 150 mW

Table 2 · K_{VS} coefficients

Table 2a · Overview (with flow divider St I (K_{VS} I) or St III (K_{VS} III))

K _{VS}	0.1 0.16 0.25	0.4	0.63	1.0	1.6	2.5	4.0	6.3	10	16	25	40	60	80	63	100	160	200	260
K _{VS} I	–				1.45	2.2	3.6	5.7	9	14.5	22	36	54	72	57	90	144	180	234
K _{VS} III	–								7.5	–	20	30	–	–	47	75	120	–	–
Seat Ø [mm]	3	6			12			24		31	38	48	63	80	63	80	100	110	130
Travel [mm]	15														30				30

Terms for control valve sizing according to DIN EN 60534, Parts 2-1 and 2-2: $F_L = 0.95$, $X_T = 0.75$

Table 2b · Versions without flow divider · Gray-shaded areas indicate versions also with pressure balancing

K _{VS}	0.1 0.16 0.25	0.4	0.63	1.0	1.6	2.5	4.0	6.3	10	16	25	40	60	80	63	100	160	200	260
DN																			
15	•	•	•	•	•	•	•												
20	•	•	•	•	•	•	•	•											
25	•	•	•	•	•	•	•	•	•										
32		•	•	•	•	•	•	•	•	•									
40		•	•	•	•	•	•	•	•	•	•								
50		•	•	•	•	•	•	•	•	•	•	•							
65											•	•	•						
80											•	•	•	•					
100															•	•	•		
125																•		•	
150																	•		•

Table 2c · Versions with flow divider St I (K_{VS} I) · Gray-shaded areas indicate versions also with pressure balancing

K _{VS}	–				1.45	2.2	3.6	5.7	9	14.5	22	36	54	72	57	90	144	180	234
DN																			
32								•	•	•									
40								•	•	•	•								
50								•	•	•	•	•							
65											•	•	•						
80											•	•	•	•					
100															•	•	•		
125																•		•	
150																	•		•

Table 2d · Versions with flow divider St III (K_{VS} III) · Gray-shaded areas indicate versions also with pressure balancing

K _{VS}	–								7.5	–	20	30	–	–	47	75	120	–	–
DN																			
50									•										
65											•								
80												•							
100															•				
125																•			
150																	•		

Table 3 · Differential pressures in bar · See notes concerning the differential pressure table on the last page

Table 3a · Valves with unbalanced plugs with metal sealing

Values specified in shaded columns apply to standard cases · Differential pressures specified in white columns apply to maximum pretensioned springs · Values in parentheses apply to 50 % travel

Bench range (bar) for actuators (cm ²)		80/240	0.2...1.0	–	0.4...2.0 (1.2...2.0)	0.6...2.2	–	–	–
		350, 700		0.4...1.2		–	0.8...2.4 (1.6...2.4)	1.4...2.3 (1.85...2.3)	–
Required supply pressure			1.2	1.4	2.2	2.4	2.6	2.5	3.4
DN	Kvs	Actuator cm ²	Δp when p ₂ = 0 bar						
15 to 25	0.1 to 0.25	80	40	–	40	40	–	–	–
		240	40	–	40	40	–	–	–
15 to 50	0.4 to 1.0	80	20	–	40	40	–	–	–
		240	40	–	40	40	–	–	–
	1.6 2.5 4.0	80	–	–	14.6	27.5	–	–	–
		240	27.5	–	40	40	–	–	–
20 to 50	6.3 10	80	–	–	2.0	5.2	–	–	–
		240	5.2	–	14.8	24.5	–	–	–
		350	9.6	24	24	–	40	40	–
		700	–	–	(40)	–	(40)	–	–
32 to 50	16	240	2.5	–	8.3	14.1	–	–	–
		350	5.2	13.6	13.6	–	30	40	–
		700	–	–	(40)	–	(40)	–	–
40 to 80	25	240	1.3	–	5.1	9.0	–	–	–
		350	3.1	8.7	8.7	–	19.9	37	–
		700	–	–	(40)	–	(40)	(40)	–
50 to 80	40	240	–	–	2.9	5.3	–	–	–
		350	–	5.1	5.1	–	12.0	23	–
		700	–	–	(40)	–	(40)	(40)	–
65 80	60	240	–	–	–	2.8	–	–	–
		350	–	2.7	2.7	–	6.7	12	–
		700	–	–	(23)	–	(31)	(36)	–
80	80	240	–	–	–	–	–	–	–
		350	–	1.4	1.4	–	4.0	8.0	–
		700	–	–	(14.1)	–	(19.2)	(22)	–
100	63	700	2.6	6.6	6.6	14.8	–	27	39
	80		1.4	3.9	3.9	9.0	–	16.5	24
	160		–	2.3	2.3	5.6	–	10.5	15.3
125	100	700	1.4	3.9	3.9	9.0	–	16.5	24
	200		–	1.9	1.9	4.5	–	8.5	12.6
150	160	700	–	2.3	2.3	5.6	–	10.5	15.3
	260		0.3	1.2	1.2	3.0	–	6.0	8.9

1) Bench range 2.1 to 3.3 bar relieved to 2.0 to 3.2 bar.

Table 3b · Valves with balanced plug with PTFE ring · Medium temperatures up to 220 °C

Bench range		bar	0.4 ... 1.2	0.4 ... 2.0	0.8 ... 2.4
Required supply pressure		bar	1.4	2.2	2.6
DN	Kvs	Actuator	p and Δp		
100	100 · 160	700 cm ²	40	40	40
125	100 · 200				
150	160 · 260				

Table 4 · Dimensions in mm for standard versions of Type 3241-1 and Type 3241-7

Valve	DN	15	20	25	32	40	50	65	80	100	125	150	
Length L	mm	130	150	160	180	200	230	290	310	350	400	480	
H1	≤ 700 cm ²	220						260		350	360	390	
H2	Cast version	44			72			98		118	148	175	
	Forged steel	53	-	70	-	92	98	-	128	-			
Actuator	cm ²	80			240			350		700			
Diaphragm Ø D		150			240			280		390			
H (700 cm ² and larger including lifting ring)		62						82		200			
H3 (Type 3271 and Type 3277 Actuators) ¹⁾		110								190			
Thread		M30 x 1.5											
α (for Type 3271 Actuator)		G ¼ (¼ NPT)						G ¾ (¾ NPT)					
α2 (for Type 3277 Actuator)		-			G ¾ (¾ NPT)								

¹⁾ Minimum clearance required to remove the actuator

Table 5 · Weights in kg for standard versions of Type 3241-1 and Type 3241-7

Valve	DN	15	20	25	32	40	50	65	80	100	125	150
Weight without actuator in kg		5	6	7	11	12	15	24	30	42	80	120
Actuator	cm ²	80			240			350		700		
Type 3271	Without	2			5			8		22		
	With handwheel	-			9			13		27		
Type 3277	Without	-			9			12		26		
	With handwheel	-			13			17		31		

Table 6 · Dimensions in mm and weights in kg for Type 3241 Valve with extension bonnet - without actuator

Valve	DN	15	20	25	32	40	50	65	80	100	125	150
Height H4		408			408			450		635	644	671
Weight in kg		8	9	10	17	18	21	32	38	60	105	150

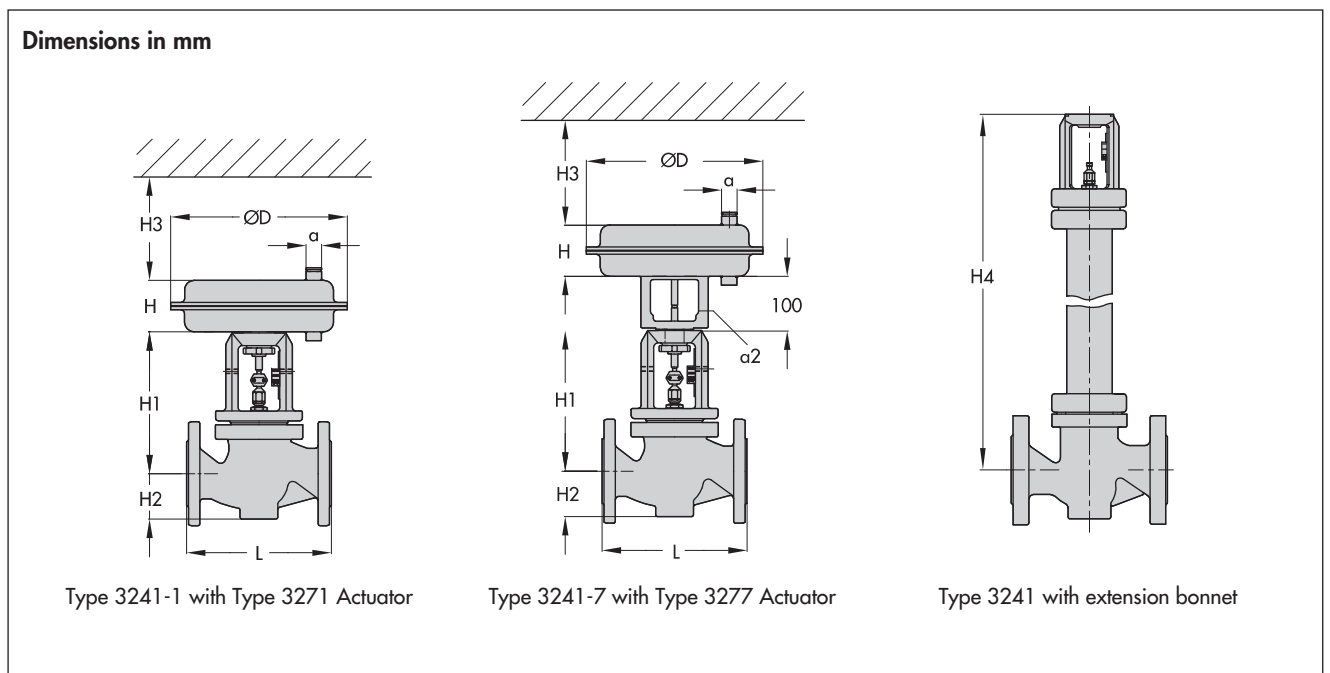

Notes concerning the differential pressures in Table 3

The differential pressure tables were prepared under the following conditions:

- Version with PTFE packing
- Direction of flow: FTO
Valve closed with a signal pressure of 0 bar
- The maximum permissible supply pressure is 4 bar for valves in nominal sizes DN 15 to DN 80 and actuators with an effective area of 700 cm²
- The leakage rates specified in Table 1 are not exceeded with the maximum differential pressures specified.
- The permissible operating pressures are restricted by the values specified in the Information Sheet T 8000-2 EN (materials and pressure-temperature diagrams).
- Only on-off valves and versions for bench ranges 0.2 bar to 1.0 bar and 0.4 bar to 1.2 bar with a required supply pressure of ≤ 1.4 bar can be used without positioners. In all other cases, a positioner is required.

The actuator sizing needs to be checked separately for versions with metal bellows seal and $p_2 \neq 0$ bar.

Ordering text

Globe valve	Type 3241
Nominal size	DN ...
Nominal pressure	PN ...
Valve body material	According to Table 1
End connections	Flanges or welding ends
Characteristic	Equal percentage or linear
Pneumatic actuator	Type 3271 or Type 3277
Effective diaphragm area	80, 240, 350 or 700 cm ²
Bench range	... bar
Solenoid valve	According to Table 1
Accessories	Positioner and/or limit switch

Specifications subject to change without notice.

