



## OPTISWIRL 4070 Technical Datasheet

### Vortex flowmeter

- Integrated pressure and temperature compensation
- Temperature compensation for saturated steam included as standard
- All OPTISWIRL versions in 2-wire technology



1 Product features	3
1.1 The all-in-one solution .....	3
1.2 Options and variants .....	5
1.3 Functional principle .....	8
2 Technical data	9
2.1 Technical data .....	9
2.2 Dimensions and weights .....	12
2.2.1 Flange versions .....	12
2.2.2 Sandwich version .....	15
2.2.3 Dimensions remote version .....	17
2.3 Flow tables .....	18
3 Installation	21
3.1 Intended use .....	21
3.2 Installation conditions .....	22
3.2.1 Measurement of liquids .....	23
3.2.2 Measurement of vapours and gases .....	25
3.2.3 Heat insulation .....	26
3.3 Inlet and outlet runs .....	27
3.3.1 Minimum inlet runs .....	27
3.3.2 Minimum outlet runs .....	28
3.3.3 Flow straightener .....	28
4 Electrical connections	29
4.1 Connecting the signal converter .....	29
4.2 Electrical connection of current and pulse output .....	30
4.3 Remote version connection .....	31
5 Order form	32
6 Notes	33

## 1.1 The all-in-one solution

The **OPTISWIRL 4070 C** is the first vortex flowmeter to feature integrated pressure and temperature compensation in 2-wire technology. The **OPTISWIRL 4070 C** provides reliable measurement of operating, standard volumetric and mass flow of conductive and non-conductive liquids, gases and vapours, even with fluctuating pressures and temperatures.

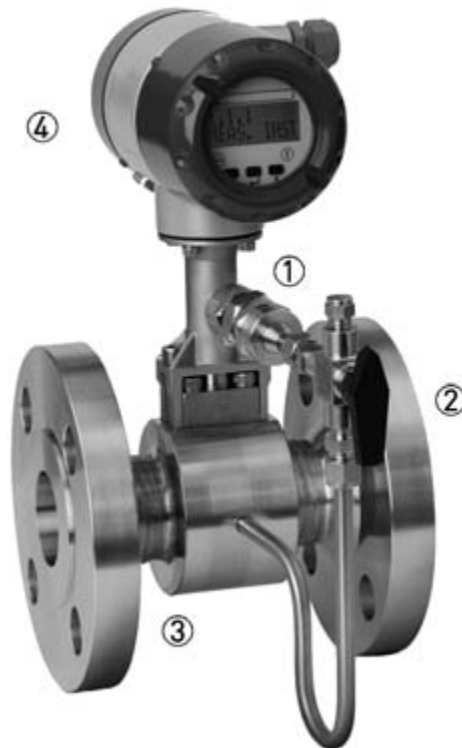

- ① Pressure sensor
- ② Shut-off valve
- ③ Fully welded stainless steel design
- ④ Converter with Intelligent Signal Processing [ISP]

**Highlights**

- 2-wire device with integrated pressure and temperature compensation
- Non-wearing, fully welded stainless steel construction with high corrosion, pressure and temperature resistance
- Optimal process reliability thanks to Intelligent Signal Processing (ISP) - stable readings, free of external perturbations
- Ready to use immediately thanks to plug & play
- Maintenance-free measuring sensor design
- PACTware available at no extra cost
- Pressure and temperature available via HART

**Industries**

- Chemicals
- Oil & Gas
- Power plants
- Food & Beverage
- Pharmaceuticals
- Iron, Steel and Metals
- Paper and pulp
- Water
- Automobile industry

**Applications**

- Vapour and saturated steam measurement
- Steam boiler monitoring
- Monitoring of compressor output
- Measurement of consumption in compressed air systems
- Measurement of consumption of industrial gases
- SIP and CIP processes in the food, beverage and pharmaceutical industries
- Measurement of conductive and non-conductive liquids

## 1.2 Options and variants

### 1. The universal device with temperature compensation for saturated steam integrated as standard



The **OPTISWIRL 4070** as a compact flowmeter in a flange version is suitable for universal use in measuring liquids, gases and vapours.

The temperature compensation for saturated steam is integrated as standard, thus enabling direct compensation of the density; the mass and energy can also be measured.

Here ISP (Intelligent Signal Processing) provides stable measurement results free of external perturbations.

### 2. The easy to install sandwich version with optimised centring rings



The **OPTISWIRL 4070** as a compact flowmeter in a sandwich version is suitable for universal use in the measurement of liquids, gases and vapours. The temperature compensation for saturated steam is integrated as standard.

The flowmeter is provided with additional optimised centring rings. The OPTISWIRL can be aligned centrally by turning the centring rings, eliminating any offset between the OPTISWIRL and the pipeline.

### 3. The only 2-wire device with integrated pressure and temperature compensation



The **OPTISWIRL 4070** as a flange or sandwich flowmeter is optionally available with integrated pressure and temperature compensation for gases, wet gases, gas mixtures or vapours. The advantages of this unique design couldn't be clearer:

- No additional cost-intensive installation of pressure and temperature sensors
- No additional cabling work
- No faulty measurement results, because pressure, temperature and volume flow can be read at a single point
- Direct measurement of mass and/or energy

### 4. The highest process availability thanks to optional shut-off valve



As an option, the **OPTISWIRL 4070** can be supplied with a shut-off valve to allow the pressure sensor to be exchanged without interrupting the process.

What is more, the pressure sensor can be shut off for the purpose of pressure or leak testing of the pipeline. Using the built-in two-way valve, the pressure sensor can also be calibrated and tested at a later time.

## 5. Dual measurement for twofold reliability



The **OPTISWIRL 4070** is optionally available as a dual version.

This is a genuine redundant system with two independent measuring sensors and two signal converters. This provides twofold functional reliability and availability of the measurement.

This variant is ideally suited for measurements in multi-product pipelines. In such pipelines, two different products are moved through one after the other.

One signal converter can be programmed for one product, and the other signal converter for the other product.

## 6. OPTISWIRL 4070 F – Field housing (remote version)



The **OPTISWIRL 4070** is also available as a remote version with a field housing converter.

This feature allows separating the signal converter from the measuring sensor up to a distance of 15 m / 49 ft in case the measuring sensor is mounted in inaccessible areas. The remote mounted signal converter allows easy operation and reading of values at eye level.

Additionally to the flow rates, measurements of the integrated pressure and temperature sensors can be displayed.

### 1.3 Functional principle

Vortex flowmeters are used to measure the volumetric flow of gases, vapours and liquids at completely filled pipes.

The measuring principle is based on the Karman vortex street. The measuring tube contains a bluff body, behind which vortex shedding occurs. The frequency  $f$  of the vortex shedding is proportional to the flow rate  $v$ . The nondimensional Strouhal number  $S$  describes the relationship between vortex frequency  $f$ , width  $b$  of bluff body and the mean flow velocity  $v$ :

$$f = \frac{S \cdot v}{b}$$

The vortex frequency is recorded at the sensor and evaluated at the converter.

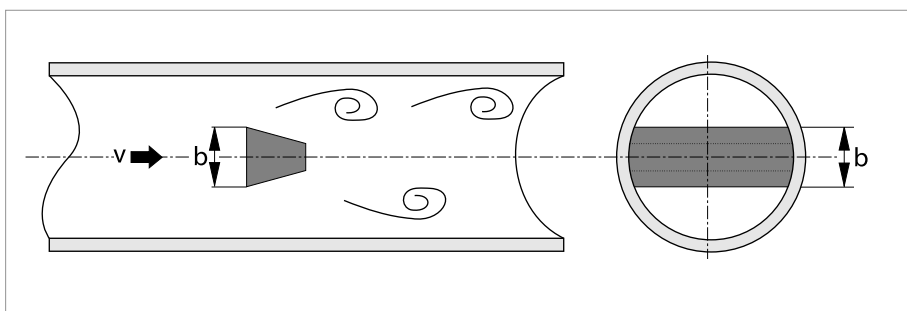

Figure 1-1: Functional principle



## 2.1 Technical data

- *The following data is provided for general applications. If you require data that is more relevant to your specific application, please contact us or your local representative.*
- *Additional information (certificates, special tools, software,...) and complete product documentation can be downloaded free of charge from the website (Download Center).*

### Measuring system

Application range	Flow measurement of liquids, gases and vapours
Operating method / measuring principle	Karman vortex street

### Measured value

Primary measured value	Number of separated vortices
Secondary measured value	Operating and standard volumetric flow, mass flow

### Signal converter

Versions	Compact
	Remote version - cable length $\leq 15\text{m}$ (49 ft)
	Option: Ex version

### Measuring sensor

Standard	Basic device in flange version (with integrated temperature measurement)
	Basic device in sandwich version (with integrated temperature measurement)
Optional	Basic device with additional pressure measurement
	Basic device with additional pressure measurement and shut-off valve for pressure sensor
	Dual measuring device in both flange and sandwich version (redundant measurement)
	Dual measuring device in flange version with additional pressure measurement

### Display and user interface

Local display	2 lines, 10 characters per line
Operating and display languages	German, English, French

### Measuring accuracy

Reference condition	Water at 20°C
	Air at 20°C and 1.013 bar abs.
Accuracy	Based on volume flow
Liquids	$\pm 0.75\%$ of measured value ( $Re \geq 20000$ )
	$\pm 2.0\%$ of measured value ( $10000 < Re < 20000$ )
Gases and steams	$\pm 1.0\%$ of measured value ( $Re \geq 20000$ )
	$\pm 2.0\%$ of measured value ( $10000 < Re < 20000$ )
	Pressure and temperature compensation: $\pm 1.5\%$ of measured value ( $Re \geq 20000$ ); $\pm 2.5\%$ of measured value ( $10000 < Re < 20000$ )
Repeatability	$\pm 0.1\%$ of measured value
Long-term stability	$\pm 0.01\%$ of measured value

## Operating conditions

### Temperature

Product	-40...+240°C / -40...+465°F
Ambient	Non-Ex: -40...+85°C / -40...+185°F
	Ex: -40...+60°C / -40...+140°F
Storage	-50...+85°C / -58...+185°F

### Pressure

Product	Max. 100 bar / 1450 psi; Information on higher pressures on request.
Ambient	Atmosphere

### Chemical properties

Density	Taken into consideration when sizing.
Viscosity	< 10 cP
Reynold's number	10000...2300000

### Recommended flow velocities

Liquids	0.3...7 m/s / 0.98...23 ft/s (optional up to 10 m/s / 32.8 ft/s taking cavitation into account)
Gases and steams	2.0...80 m/s / 6.6...262.5 ft/s
	DN15: 3.0...45 m/s / 9.8...148 ft/s; DN25: 2.0...70 m/s / 6.6...230 ft/s
	For detailed information, see chapter "Flow tables".

### Other conditions

Protection category	IP 66/67
---------------------	----------

### Installation conditions

Inlet run	≥ 20 x DN (without disturbing flow, after pipe narrowing, after a single 90° bend)
	≥ 30 x DN (after a double bend 2x90°)
	≥ 40 x DN (after a double three-dimensional bend 2x90°)
	≥ 50 x DN (after control valves)
	≥ 2 DN before flow straightener; ≥ 8 DN after flow straightener (specified values apply only to original ≥ 20 DN inlet run)
Outlet run	≥ 5 x DN
Dimensions and weights	For detailed information refer to chapter "Dimensions and weights".

### Materials

Measuring sensor and process connections	Standard: 1.4404/316L
	Option: Hastelloy® C-22 on request
Converter housing	Die-cast Aluminium
Pressure sensor gasket	Standard: FPM
	Option: FFKM

Measuring tube gasket	Standard: 1.4435/316L
	Option: Hastelloy® C-276
	Selection depends on measuring sensor material/medium.

### Process connections Flange version

DIN EN 1092-1	DN15...300 in PN16...100
ASME B16.5	½...12" in 150...600 lb
JIS B 2220	DN15...300 in JIS 10...20 K
	For detailed information on combination flange/pressure rating, refer to chapter "Dimensions and weights".

### Process connections Sandwich version

DIN	DN15...100 in PN100 (higher pressures on request)
ASME	½...4" in 600 lb (higher pressures on request)
JIS	DN15...100 in 10...20 K (higher pressures on request)

### Electrical connections

Power supply	Non-Ex: 14...36 VDC
	Ex: 14...30 VDC

### Current output

Description of the used abbreviations	$U_{ext}$ = external voltage; $R_L$ = load + resistance
Measuring range	4...20 mA (max. 20.8 mA) + HART® protocol
Load	Minimum 0 $\Omega$ ; maximum $R_L = ((U_{ext} - 14 \text{ VDC}) / 22 \text{ mA})$
Error signal	Acc. to NAMUR NE43
	Upper value: $\geq 21.0 \text{ mA}$
	Lower value: $\leq 3.6 \text{ mA}$ (not with HART® protocol)

### Pulse output

Pulse rate	Max. 0.5 pulse/s (corresponds to 1800 pulses/hour)
Power supply	Non-Ex: 24 VDC as NAMUR or open < 1 mA, maximum 36 V, closed 100 mA, $U < 2 \text{ V}$
	Ex: 24 VDC as NAMUR or open < 1 mA, maximum 30 V, closed 100 mA, $U < 2 \text{ V}$

### HART®

	HART® protocol via current output
Device revision	1
Physical layer	FSK
Device category	Transmitter, galvanically isolated
System requirements	Load min. 250 $\Omega$
Multidrop operation	4 mA

### Approvals and certifications

ATEX	ATEX II 2G Ex d ia [ia] IIC T6
FM	Class I, II, III Div 1/2, groups A-G

## 2.2 Dimensions and weights

### 2.2.1 Flange versions

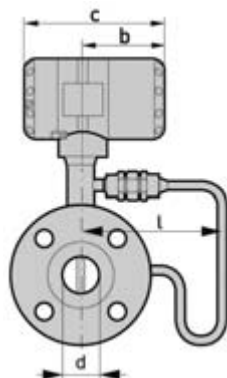
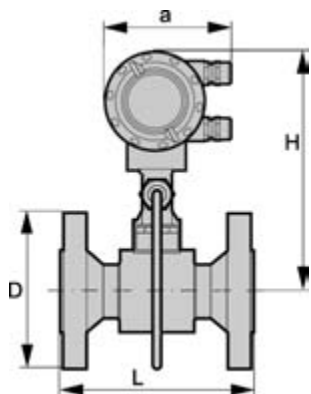

Option: version with 2 transmitters

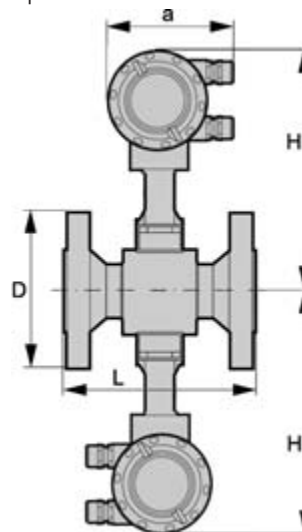

a = 135 mm / 5.32"

b = 108 mm / 4.26"  
c = 184 mm / 7.25"

Dimension H x 2  
Specified weight + 2.80 kg

### Flange version EN 1092-1

Size DN	Pressure rating PN	Dimensions [mm]					Weight [kg]	
		d	D	L	H	l	With pressure sensor	Without
15	40	17.3	95	200	265	174.3	6.1	5.5
15	100	17.3	105	200	265	174.3	7.1	6.5
25	40	28.5	115	200	265	174.3	7.9	7.3
25	100	28.5	140	200	265	174.3	9.9	9.3
40	40	43.1	150	200	270	174.5	10.8	10.2
40	100	42.5	170	200	270	174.5	14.8	14.2
50	16	54.5	165	200	275	174.5	12.7	12.1
50	40	54.5	165	200	275	174.5	12.9	12.3
50	63	54.5	180	200	275	174.5	16.9	16.3
50	100	53.9	195	200	275	174.5	18.4	17.8
80	16	82.5	200	200	290	174.25	17.4	16.8
80	40	82.5	200	200	290	174.25	19.4	18.8
80	63	81.7	215	200	290	174.25	23.4	22.8
80	100	80.9	230	200	290	174.25	27.4	26.8
100	16	107.1	220	250	310	174.5	22	21.4
100	40	107.1	235	250	310	174.5	25	24.4
100	63	106.3	250	250	310	174.5	30	29.4

Size	Pressure rating	Dimensions [mm]					Weight [kg]	
DN	PN	d	D	L	H	l	With	Without
							pressure sensor	
100	100	104.3	265	250	310	174.5	36	35.4
150	16	159.3	285	300	325	196.5	35.8	35.2
150	40	159.3	300	300	325	196.5	41.8	41.2
150	63	157.1	345	300	325	196.5	59.8	59.2
150	100	154.1	355	300	325	196.5	67.8	67.2
200	10	206.5	340	300	350	208.5	38.4	37.8
200	16	206.5	340	300	350	208.5	38.4	37.8
200	25	206.5	360	300	350	208.5	47.4	46.8
200	40	206.5	375	300	350	208.5	55.4	54.8
250	10	260.4	395	380	370	236.5	58.0	57.4
250	16	260.4	405	380	370	236.5	59.0	58.4
250	25	258.8	425	380	370	236.5	75.0	74.4
250	40	258.8	450	380	370	236.5	93.0	92.4
300	10	309.7	445	450	395	261	76.3	75.7
300	16	309.7	460	450	395	261	82.8	82.2
300	25	307.9	485	450	395	261	99.3	98.7
300	40	307.9	515	450	395	261	128.1	127.5

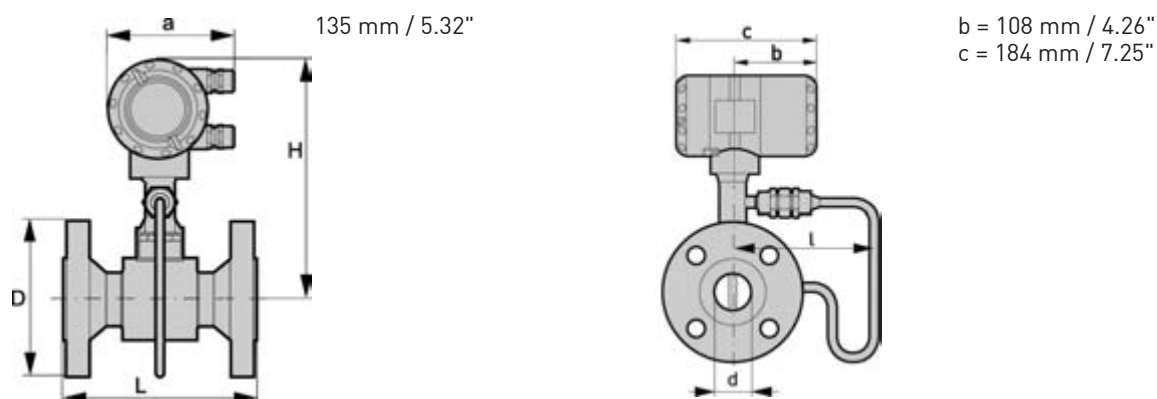

Flange version ASME B16.5

Size	Pressure rating	Dimensions [mm / inches]					Weight [kg / lb]	
		d	D	L	H	l	With	Without
NPS	Class	pressure sensor						
½	150	15.8 / 0.6	90 / 3.5	200 / 7.9	265 / 10.4	174.3 / 6.9	5.1 / 11.2	4.5 / 9.9
½	300	15.8 / 0.6	95 / 3.7	200 / 7.9	265 / 10.4	174.3 / 6.9	5.5 / 12.1	4.9 / 10.8
½	600	13.9 / 0.5	95 / 3.7	200 / 7.9	265 / 10.4	174.3 / 6.9	5.7 / 12.6	5.1 / 11.2
1	150	26.6 / 1.1	110 / 4.3	200 / 7.9	265 / 10.4	174.3 / 6.9	6.8 / 15.0	6.2 / 13.7
1	300	26.6 / 1.1	125 / 4.9	200 / 7.9	265 / 10.4	174.3 / 6.9	7.8 / 17.2	7.2 / 15.9
1	600	24.3 / 1.0	125 / 4.9	200 / 7.9	265 / 10.4	174.3 / 6.9	8.1 / 17.9	7.5 / 16.5
1½	150	40.9 / 1.6	125 / 4.9	200 / 7.9	270 / 10.6	174.3 / 6.9	8.9 / 19.9	8.3 / 18.3
1½	300	40.9 / 1.6	155 / 6.1	200 / 7.9	270 / 10.6	174.3 / 6.9	11 / 24.3	10.4 / 22.9
1½	600	38.1 / 1.5	155 / 6.1	200 / 7.9	270 / 10.6	174.3 / 6.9	12 / 26.5	11.4 / 25.1
2	150	52.6 / 2.1	150 / 5.9	200 / 7.9	275 / 10.8	174.3 / 6.9	11.6 / 25.6	11 / 24.3
2	300	52.6 / 2.1	165 / 6.5	200 / 7.9	275 / 10.8	174.3 / 6.9	13 / 28.7	12.4 / 27.4
2	600	49.3 / 1.9	165 / 6.5	200 / 7.9	275 / 10.8	174.3 / 6.9	14.5 / 32.0	13.9 / 30.6
3	150	78 / 3.1	190 / 7.5	200 / 7.9	290 / 11.4	174.5 / 6.9	20.4 / 45.0	19.8 / 43.7
3	300	78 / 3.1	210 / 8.3	200 / 7.9	290 / 11.4	174.5 / 6.9	23.4 / 51.6	22.8 / 50.2
3	600	73.7 / 2.9	210 / 8.3	200 / 7.9	290 / 11.4	174.5 / 6.9	24.4 / 52.8	23.8 / 52.5
4	150	102.4 / 4.0	230 / 9.1	250 / 9.8	310 / 12.2	176.5 / 7.0	24 / 52.9	23.4 / 51.6
4	300	102.4 / 4.0	255 / 10.0	250 / 9.8	310 / 12.2	176.5 / 7.0	32 / 70.6	31.4 / 69.2
4	600	97.2 / 3.8	275 / 10.8	250 / 9.8	310 / 12.2	176.5 / 7.0	41 / 90.4	40.4 / 89.1
6	150	154.2 / 6.1	280 / 11.0	300 / 11.8	325 / 12.8	196.5 / 7.7	36.8 / 81.1	36.2 / 79.8
6	300	154.2 / 6.1	320 / 12.6	300 / 11.8	325 / 12.8	196.5 / 7.7	51.8 / 114.2	51.2 / 112.9
6	600	146.3 / 5.8	355 / 14.0	300 / 11.8	325 / 12.8	196.5 / 7.7	76.8 / 169.3	46.2 / 101.9
8	150	202.7 / 8.0	345 / 13.6	300 / 11.8	350 / 13.8	208.5 / 8.2	50.6 / 146.4	50.0 / 145.7
8	300	202.7 / 8.0	380 / 15.0	300 / 11.8	350 / 13.8	208.5 / 8.2	75.4 / 190.4	74.8 / 189.7
10	150	254.5 / 10.0	405 / 15.5	380 / 15.0	370 / 14.6	236.5 / 9.3	75.0 / 197.1	74.4 / 195.8
10	300	254.5 / 10.0	455 / 17.9	380 / 15.0	370 / 14.6	236.5 / 9.3	107.0 / 252.2	106.4 / 239.9
12	150	304.8 / 1	485 / 19.1	450 / 17.7	395 / 15.6	261 / 10.3	106.9 / 318.3	106.3 / 317.0
12	300	304.8 / 1	520 / 20.5	450 / 17.7	395 / 15.6	261 / 10.3	151.9 / 415.4	151.3 / 414.0

## 2.2.2 Sandwich version

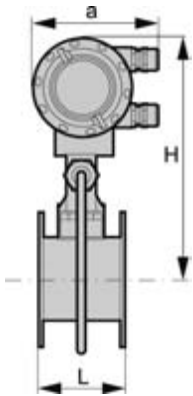

a = 135 mm / 5.32"

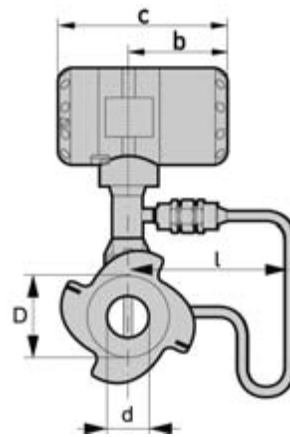

b = 108 mm / 4.26"  
c = 184 mm / 7.25"

## Sandwich version EN

Size DN	Pressure rating PN	Dimensions [mm]					Weight [kg]	
		d	D	L	H	l	With pressure sensor	Without pressure sensor
15	100	16	45	65	265	174.25	4.1	3.5
25	100	24	65	65	265	174.25	4.9	4.3
40	100	38	82	65	270	174.5	5.5	4.9
50	100	50	102	65	275	174.5	6.6	6
80	100	74	135	65	290	174.25	8.8	8.2
100	100	97	158	65	310	176.5	10.1	9.5

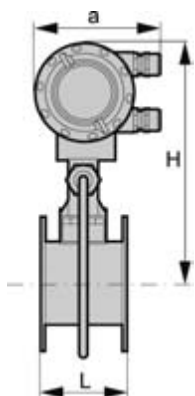

a = 135 mm / 5.32"

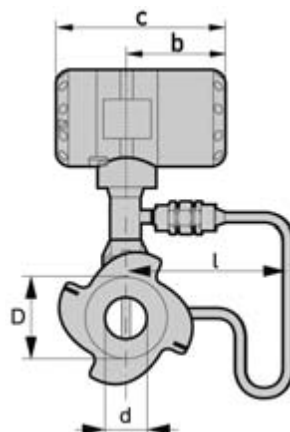

b = 108 mm / 4.26"  
c = 184 mm / 7.25"

Sandwich version ASME

Size NPS	Pressure rating Class	Dimensions [inches]					Weight [lb]	
		d	D	L	H	l	With pressure sensor	Without
½	150	0.63	1.77	2.56	10.43	6.82	9.04	7.72
½	300	0.63	1.77	2.56	10.43	6.82	9.04	7.72
½	600	0.55	1.77	2.56	10.43	6.82	9.04	7.72
1	150	0.94	2.56	2.56	10.43	6.82	10.8	9.48
1	300	0.94	2.56	2.56	10.43	6.82	10.8	9.48
1	600	0.94	2.56	2.56	10.43	6.82	10.8	9.48
1½	150	1.5	3.23	2.56	10.63	6.87	12.13	10.8
1½	300	1.5	3.23	2.56	10.63	6.87	12.13	10.8
1½	600	1.5	3.23	2.56	10.63	6.87	12.13	10.8
2	150	1.97	4.02	2.56	10.83	6.87	14.55	13.23
2	300	1.97	4.02	2.56	10.83	6.87	14.55	13.23
2	600	1.97	4.02	2.56	10.83	6.87	14.55	13.23
3	150	2.91	5.31	2.56	11.42	6.82	19.4	18.08
3	300	2.91	5.31	2.56	11.42	6.82	19.4	18.08
3	600	2.91	5.31	2.56	11.42	6.82	19.4	18.08
4	150	3.82	6.22	2.56	12.21	6.95	22.27	20.94
4	300	3.82	6.22	2.56	12.21	6.95	22.27	20.94
4	600	3.82	6.22	2.56	12.21	6.95	22.27	20.94



## 2.2.3 Dimensions remote version

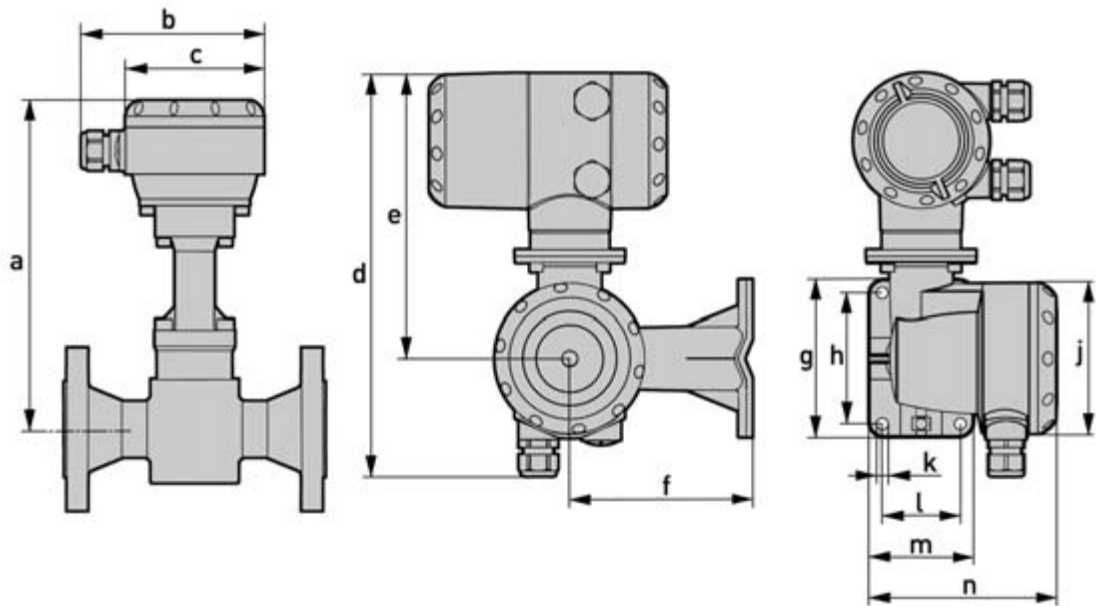

## Dimension a

	Flanged version										
	Sandwich version						-				
DN ▶	15	25	40	50	80	100	150	200	250	300	
NPS ▶	½	1	1½	2	3	4	6	8	10	12	
[mm] ▶	248	248	253	258	273	293	308	333	353	378	
["] ▶	9.77	9.77	9.97	10.2	10.8	11.5	12.1	13.1	13.9	14.9	

	b	c	d	e	f	g	h	j	k	l	m	n
[mm]	140	∅ 106	310	219	140	120	100	∅ 115	∅ 9 (4x)	60	80	144
["]	5.52	∅ 4.18	12.2	8.63	5.52	4.73	3.94	∅ 4.53	∅ 0.36 (4x)	2.36	3.15	5.67

## 2.3 Flow tables

### Measuring ranges

Size		Q <sub>min</sub>	Q <sub>max</sub>	Q <sub>min</sub>	Q <sub>max</sub>
DN - EN 1092-1	NPS - ASME B16.5	[m <sup>3</sup> /h]		[gph]	

### Water

15	½	0.45	5.0	119	1321
25	1	0.81	11.40	214	3012
40	1½	2.04	28.57	539	7547
50	2	3.53	49.47	933	13069
80	3	7.74	108.37	2045	28629
100	4	13.30	186.21	3514	49192
150	6	30.13	421.86	7960	111445
200	8	52.66	792.42	13911	209335
250	10	90.5	1266.8	23908	334653
300	12	113.41	1839.8	29960	486024
Values based on water at 20°C / 68°F					

### Air

15	½	6.79	32.56	1794	8602
25	1	10.20	114.0	2695	30116
40	1½	25.35	326.63	6697	86287
50	2	43.89	565.49	11595	149388
80	3	96.14	1238.60	25398	327207
100	4	165.19	2128.27	43639	562236
150	6	374.23	4821.57	98862	1273738
200	8	702.95	9056.8	185700	2392553
250	10	1123.7	14478	29685	3824683
300	12	1632.1	21028	431155	55550104
Values based on air at 20°C / 68°F and 1.013 bar abs / 14.891 psig					

### Flow rate limits

Product	Nominal sizes		Minimum flow rates		Maximum flow rates	
	EN	ASME	[m/s]	[ft/s]	[m/s]	[ft/s]
Liquids	DN15...300	½...12"	$0.5x(998/\rho)^{0.5}$ ①	$1.64x(998/\rho)^{0.5}$ ②	$7x(998/\rho)^{0.47}$ ①	$23x(998/\rho)^{0.47}$ ②
Gas, steam	DN15...300	½...12"	$6x(1.29/\rho)^{0.5}$ ③	$16.4x(1.29/\rho)^{0.5}$ ④	$7x(998/\rho)^{0.47}$ ③	$23x(998/\rho)^{0.47}$ ④
$\rho$ = operating density [kg/m <sup>3</sup> ]						

① Minimum flow rate 0.3 m/s - maximum flow rate 7 m/s

② Minimum flow rate 0.984 ft/s - maximum flow rate 23 ft/s

③ Minimum flow rate 2 m/s - maximum flow rate 80 m/s; DN15 up to 45 m/s and DN25 up to 70 m/s

④ Minimum flow rate 6.6 ft/s - maximum flow rate 262 ft/s; DN15 up to 148 ft/s and DN25 up to 230 ft/s

## Measuring range saturated steam: 1...7 bar

Overpressure [bar]		1		3.5		5.2		7	
Density [kg/m <sup>3</sup> ]		1.13498		2.4258		3.27653		4.16732	
Temperature [°C]		120.6		148.2		160.4		170.6	
Flow rate		min.	max.	min.	max.	min.	max.	min.	max.
DN EN 1092-1	NPS ASME B16.5	[kg/h]		[kg/h]		[kg/h]		[kg/h]	
15	½	5.87	36.97	7.68	79.0	8.93	106.68	10.06	135.69
25	1	11.82	129.39	17.28	276.40	20.09	373.53	22.66	474.82
40	1½	29.64	370.71	43.33	792.33	50.63	1070.2	56.8	1361.2
50	2	51.31	641.82	75.02	1371.8	87.19	1852.8	98.33	2356.6
80	3	112.41	1405.8	164.33	3004.7	191	4058.4	215.39	5161.8
100	4	193.14	2415.5	282.36	5162.7	328.16	6973.3	370.09	8869.2
150	6	437.56	5472.4	639.69	11696	743.45	15798	838.44	20093
200	8	821.91	10279	1201.6	21970	1396.5	29675	1574.9	37743
250	10	1313.9	16433	1920.9	35122	2232.5	47439	2517.7	60337
300	12	1908.3	23866	2789.8	51010	3242.4	68899	3656.6	87630

## Measuring range saturated steam: 10.5...20 bar

Overpressure [bar]		10.5		14		17.5		20	
Density [kg/m <sup>3</sup> ]		5.88803		7.60297		9.31702		10.5442	
Temperature [°C]		186.2		198.5		208.5		215	
Flow rate		min.	max.	min.	max.	min.	max.	min.	max.
DN EN 1092-1	NPS ASME B16.5	[kg/h]		[kg/h]		[kg/h]		[kg/h]	[kg/h]
15	½	12.78	191.71	16.51	247.55	20.23	303.36	22.89	343.32
25	1	26.93	670.88	30.6	857.88	33.87	955.48	36.04	1201.41
40	1½	67.51	1878.2	76.72	2150.7	84.93	2395.3	90.35	2557.7
50	2	116.89	3251.7	132.82	3723.4	147.03	4147	156.42	4428.1
80	3	256.03	7122.4	290.93	8155.8	322.06	9083.7	342.62	9699.3
100	4	439.91	12238	499.9	14013	553.38	15608	588.69	16666
150	6	996.62	27725	1132.5	31747	1253.7	35359	1333.7	37756
200	8	1872.1	52079	2127.3	59634	2354.9	66419	2505.2	70921
250	10	2992.7	83254	3400.71	95333	3764.6	106180	4004.9	113380
300	12	4346.5	120920	4939.1	138460	5467.5	154210	5816.5	164660

## Measuring range saturated steam: 15...100 psig

Overpressure [psig]		15		50		75		100	
Density [lb/ft <sup>3</sup> ]		0.0719		0.1497		0.2036		0.2569	
Temperature [°F]		249.98		297.86		320.36		338.184	
Flow rate		min.	max.	min.	max.	min.	max.	min.	max.
DN EN 1092-1	NPS ASME B16.5	[lb/h]		[lb/h]		[lb/h]		[lb/h]	[lb/h]
15	½	12.9	82.70	16.83	1720.12	19.62	234.0	22.04	295.23
25	1	26.25	289.40	37.86	602.09	44.15	818.63	49.59	1032.76
40	1½	65.81	829.61	94.92	1726	110.68	2346.7	124.32	2960.5
50	2	113.94	1436.3	164.34	2988	191.63	4062.9	215.23	5125.6
80	3	249.57	3146.1	360	6545.3	419.74	8899.4	471.45	11227
100	4	428.81	5405.7	618.51	11246	721.21	15291	810.06	19291
150	6	971.47	12246	1401.2	25478	1633.9	34642	1835.2	43703
200	8	1824.8	23004	2632.1	47859	3069.1	65072	3447.2	82092
250	10	2917.2	36774	4207.7	76508	4906.4	104030	5510.8	131230
300	12	4236.8	53410	6111.1	111120	7125.8	151080	8003.6	190600

## Measuring range saturated steam: 150...300 psig

Overpressure [psig]		150		200		250		300	
Density [lb/ft <sup>3</sup> ]		0.3627		0.4681		0.5735		0.6792	
Temperature [°F]		366.08		388.04		406.22		422.06	
Flow rate		min.	max.	min.	max.	min.	max.	min.	max.
DN EN 1092-1	NPS ASME B16.5	[lb/h]		[lb/h]		[lb/h]		[lb/h]	[lb/h]
15	½	27.79	416.68	35.86	573.83	43.94	659.14	52.04	780.29
25	1	58.93	1459.16	66.94	1875.90	74.1	2089.00	80.63	2284.90
40	1½	147.72	4107.2	167.83	4702.8	185.76	5237	202.15	5728
50	2	255.75	7111.9	290.56	8141.9	321.6	9066.8	350	9917
80	3	560.19	15578	636.44	17834	704.43	19860	766.6	21722
100	4	962.54	26766	1093.5	30643	1210.4	34124	1317.2	37324
150	6	2180.6	60639	2477.4	69421	2742.1	77307	2984	84556
200	8	4096.1	113900	4653.6	130400	5150.7	145210	5605.2	158830
250	10	6548.1	182090	7439.3	208460	8234.1	232140	8960.6	253910
300	12	9510.2	264460	10805	302760	11959	337150	13014	368770

### 3.1 Intended use

The vortex flowmeters are made to measure the flow of gases, vapours and liquids.

**The devices are particularly suitable for the measurement of:**

- Clean liquids with low viscosity (< 10 cP)
- Hydrocarbons with low viscosity (< 10 cP)
- Water
- Chemicals with low corrosiveness
- Saturated steam
- Superheated steam, including CIP and SIP applications in the food industry
- Industrial gases

**The devices are rated for the following flow velocities:**

- Liquids: 0.3...7 m/s / 1.0...23 ft/s
- Gases and steam: 2.0...80 m/s / 6.6...262 ft/s  
DN15: 3.0...45 m/s / 9.8...148 ft/s; DN25: 2.0...70 m/s / 6.6...230 ft/s

If the danger of waterhammers can occur in steam networks appropriate condensate separators have to be installed.

Suitable measures must be taken to avoid water cavitation if it is a possible risk.

*Responsibility for the use of the measurement devices with regard to suitability, intended use and corrosion resistance of the used materials against the measured fluid lies solely with the operator.*

- The sensors are made from Stainless Steel 316 L (1.4404) or Hastelloy® C22.
- In your project planning, please observe the data given in the corrosion tables.
- The pressure-bearing parts have been designed and rated for stationary operation taking into account the maximum pressure and temperature.
- Observe the data indicated on the nameplate for PS, TS and PT (PED 97/23/EC).
- External forces and moments, caused e.g. by pipe stresses, have not been taken into account.

Primarily, volumetric flow and temperature are measured, with pressure measurement as an option. From these parameters the measuring device calculates the mass flow or standard volumetric flow using pre-programmed density data and then exports the measured values via various communication interfaces.

## 3.2 Installation conditions

*For accurate volumetric flow measurement the measuring device needs a completely filled pipe and a fully developed flow profile.*

*Please observe the instructions regarding inlet and outlet pipe runs as well as the installation position.*

*In the event of vibrations on the piping, select the installation site so that the vibrations are at their lowest in a transverse direction to the flowmeter.*

***When installing the device in the piping, the following points must be observed:***

- *Nominal diameter of connection pipe flange = nominal flange diameter of pipe!*
- *Use flanges with smooth holes, e.g. welding neck flanges.*
- *Align carefully the holes of the connecting flange and the flowmeter flange.*
- *Check the compatibility of the gasket material with the process product.*
- *Make sure that the gaskets are arranged concentrically. The flange gaskets must not project into the pipe cross-section.*
- *The flanges have to be concentric.*
- *There must not be any pipe bends, valves, flaps or other internals in the immediate inlet run.*
- *Devices in sandwich version may only be installed using a centering ring.*
- *Never install the device directly behind piston compressors or rotary piston meters.*
- *Do not lay signal cables directly next to cables for the power supply.*

*If the danger of waterhammers can occur in steam networks appropriate condensate separators have to be installed.*

*Suitable measures must be taken to avoid water cavitation if it is a possible risk.*

### 3.2.1 Measurement of liquids

#### Prohibited installation

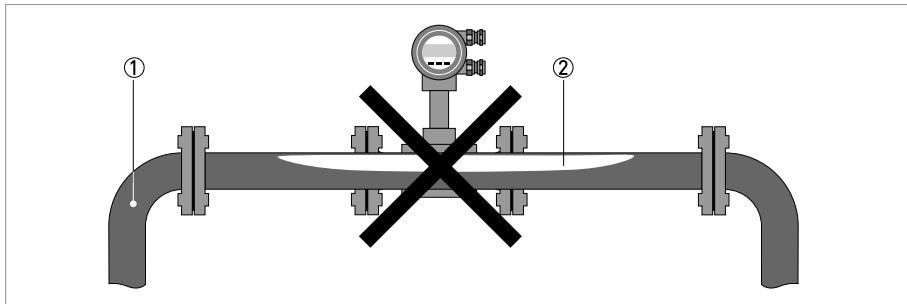

Figure 3-1: Upper pipe bend

*Prohibited: Installing the device in an upper pipe bend ①, because there is a risk of gas bubbles ② forming. Gas bubbles can lead to pressure surges and inaccurate measurement.*

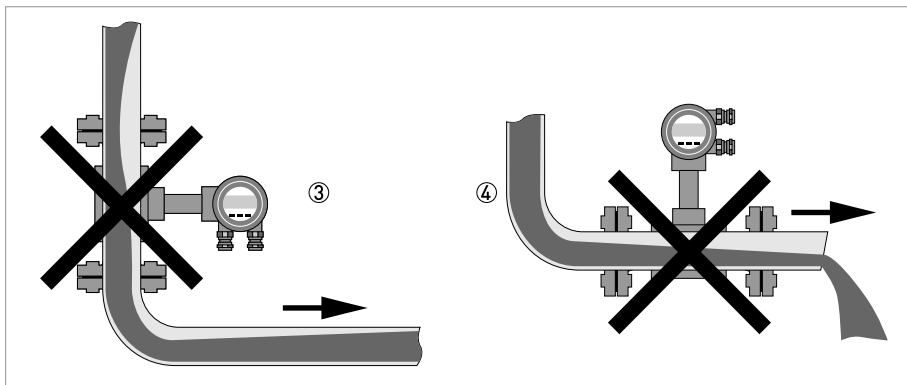
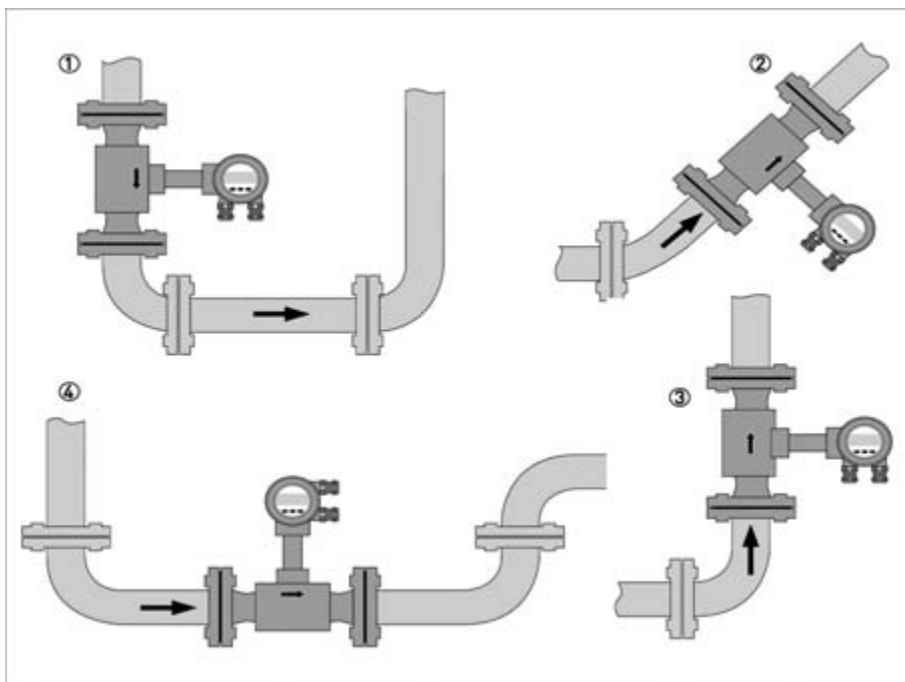

Figure 3-2: Downpipe and outlet

*Prohibited: Installing the device in a downstream pipe ③ or upstream pipe of a outlet ④. There is the risk of partially filled pipes.*

### Recommended installations for measurement of liquids

*It is absolutely necessary to comply with the required inlet and outlet runs.*



- ① If the device is installed in a downpipe, a standpipe must be installed immediately after it.
- ② Installing the device in an inclined standpipe.
- ③ Installing the device in a vertical standpipe.
- ④ Installing the device in the lower pipe bend.

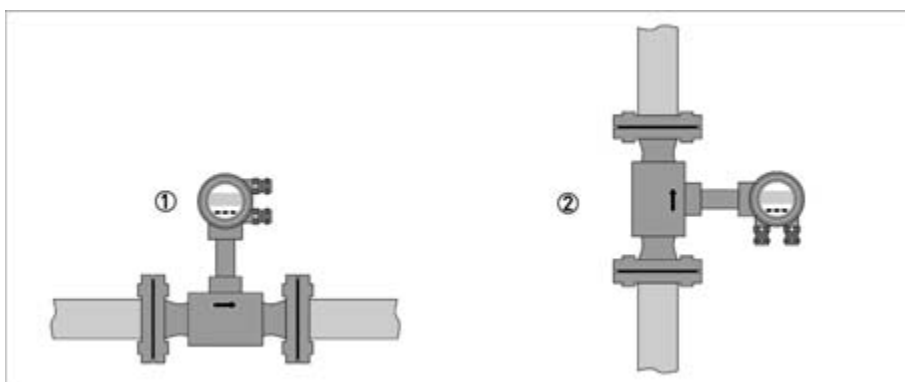

- ① Above a horizontal pipe
- ② On a vertical pipe

*Depending on the installation position, you may have to rotate the display and/or the connection housing.*



### 3.2.2 Measurement of vapours and gases

#### Prohibited installation

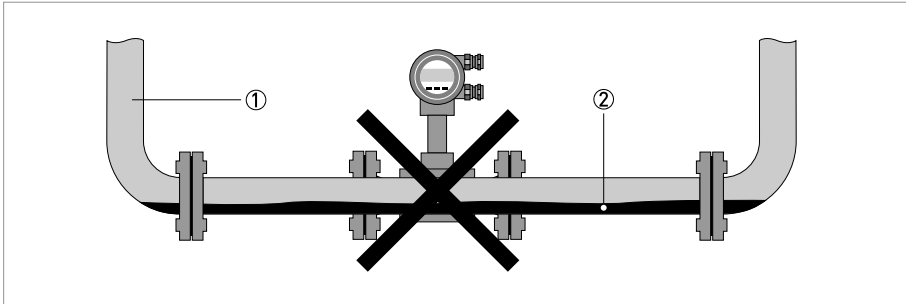

- ① Lower pipe bends
- ② Condensate

*Prohibited: Installing the device in a lower pipe bend ①, because there is a risk of condensate forming ②.*

*Condensate can lead to cavitation and inaccurate measurement. Under certain circumstances the device can be destroyed and the measured product can leak.*

#### Recommended installations

*It is absolutely necessary to maintain the required inlet and outlet runs.*

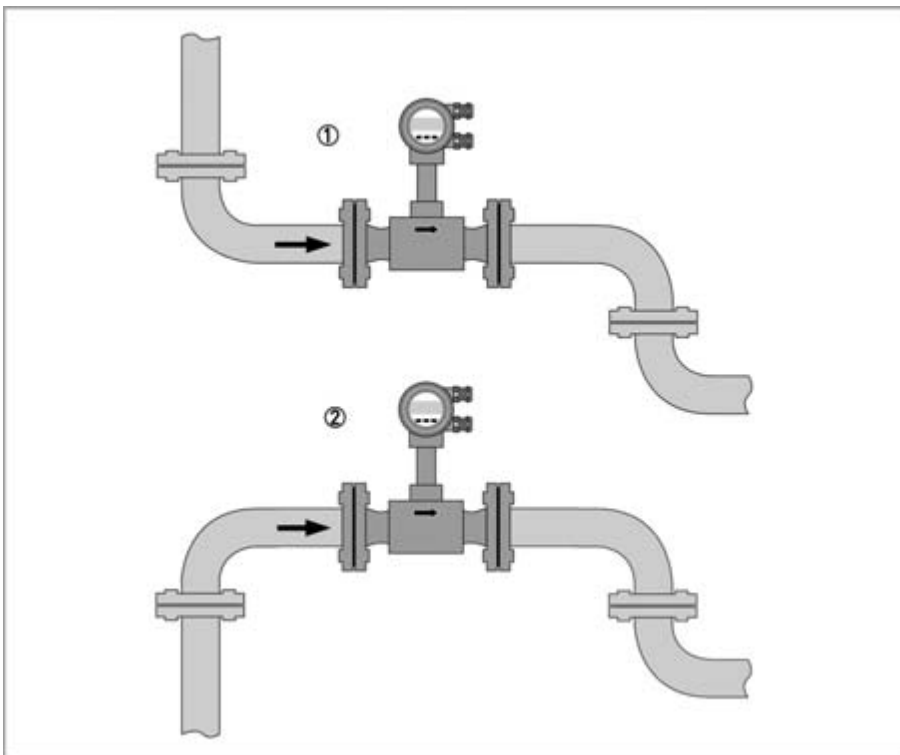

- ① Inlet and outlet falling
- ② Rising inlet - falling outlet

### 3.2.3 Heat insulation

*The area above the converter support must not be heat-insulated.  
The heat insulation ③ may only extend to the maximum height ① shown below up to the connecting screws of the measuring sensor.*

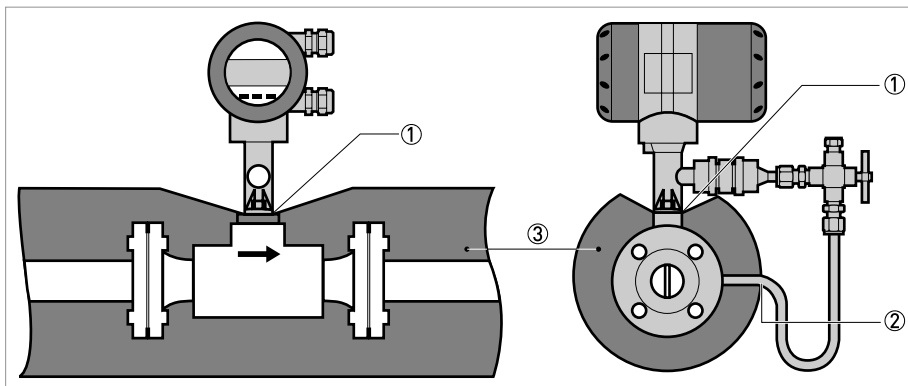

Figure 3-3: Heat insulation on connection piece and signal cable

- ① Max. height of insulation up to intermediate piece between measuring sensor and signal converter
- ② Max. thickness of the insulation up to the bend of the pressure pipe
- ③ Insulation

*The heat insulation ③ may only extend as far as the bend of the pressure sensing line ②.*

### 3.3 Inlet and outlet runs

#### 3.3.1 Minimum inlet runs

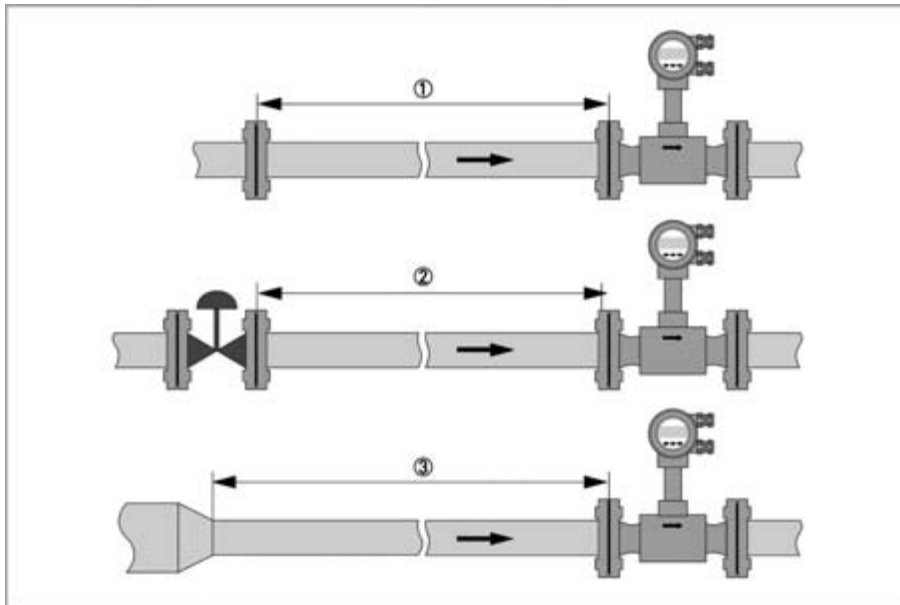

- ① General inlet run without disturbing flow  $\geq 20$  DN
- ② Behind a control valve  $\geq 50$  DN
- ③ After a pipe diameter reduction  $\geq 20$  DN

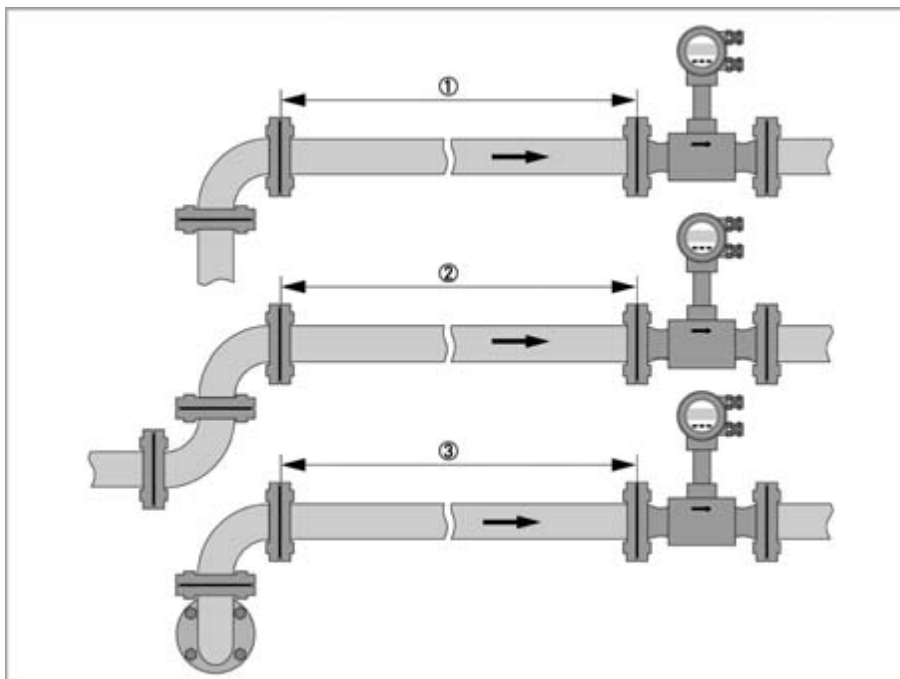

- ① After a single bend  $90^\circ \geq 20$  DN
- ② After a double bend  $2 \times 90^\circ \geq 30$  DN
- ③ After a double three-dimensional bend  $2 \times 90^\circ \geq 40$  DN

### 3.3.2 Minimum outlet runs

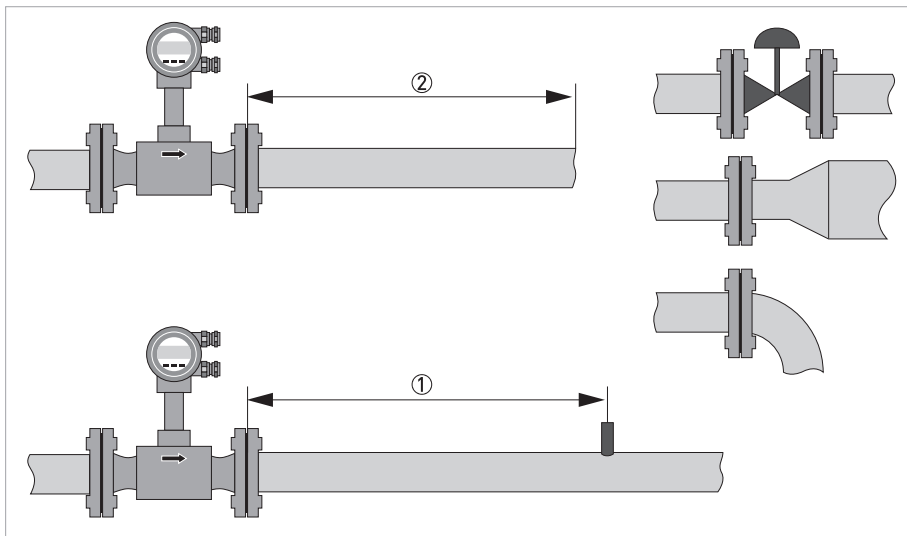

Figure 3-4: Minimum outlet runs

- ① Upstream of pipe expanders, pipe bends, control valves, etc.  $\geq 5$  DN
- ② Upstream of metering points  $\geq 5 \dots 6$  DN

*The interior of the pipe at the metering points must be free of burrs and other flow impediments. The measuring device has an internal temperature sensor. External temperature sensor must be located  $\geq 5$  DN behind the flow sensor outlet. Use sensors that are as short as possible to avoid disturbing the flow profile.*

### 3.3.3 Flow straightener

If, due to the type of installation, the required inlet runs are not available, the manufacturer recommends using flow straighteners. Flow straighteners are installed between two flanges upstream of the device and shorten the required inlet run.

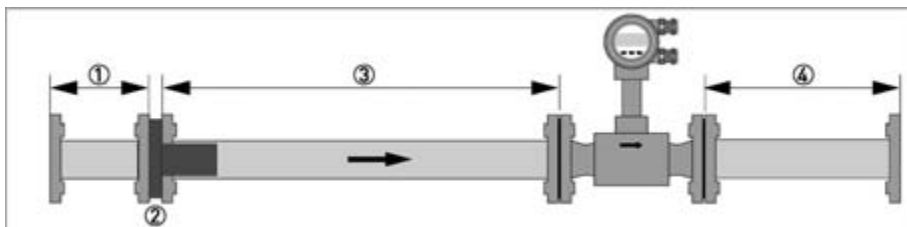

Figure 3-5: Flow straightener

- ① Straight inlet run upstream of straightener  $\geq 2$  DN
- ② Flow straightener
- ③ Straight pipe run between flow straightener and device  $\geq 8$  DN
- ④ Minimum straight outlet run  $\geq 5$  DN

## 4.1 Connecting the signal converter

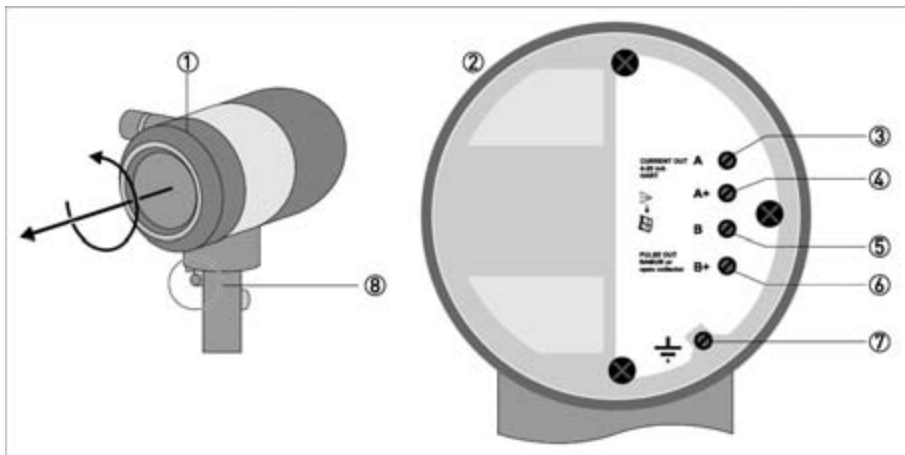

Figure 4-1: Signal converter housing with housing cover

- ① Housing cover of the electrical terminal compartment
- ② Electrical connection terminals with the housing cover open
- ③ Terminal A current output -
- ④ Terminal A+ current output +
- ⑤ Terminal B pulse output -
- ⑥ Terminal B+ Pulse output +
- ⑦ PE terminal in housing
- ⑧ PE terminal on connection piece between measuring sensor and signal converter.

Both grounding terminals ⑦ and ⑧ are equally effective from a technical point of view.

## 4.2 Electrical connection of current and pulse output

- **Current output:**  
In some cases, a shielded or twisted cable may be necessary. The cable shield may only be earthed (grounded) at one place (on the power supply unit).
- **Pulse output:**  
When using the pulse output, two separate signal circuits are necessary if the pulse output is utilized together with analogue signals. Each signal circuit requires its own power supply. The total resistance must be adapted so that the total current  $I_{tot}$  does not exceed 100 mA.
- Connection current output on terminals A, A+  
Connection pulse output on terminals B, B+

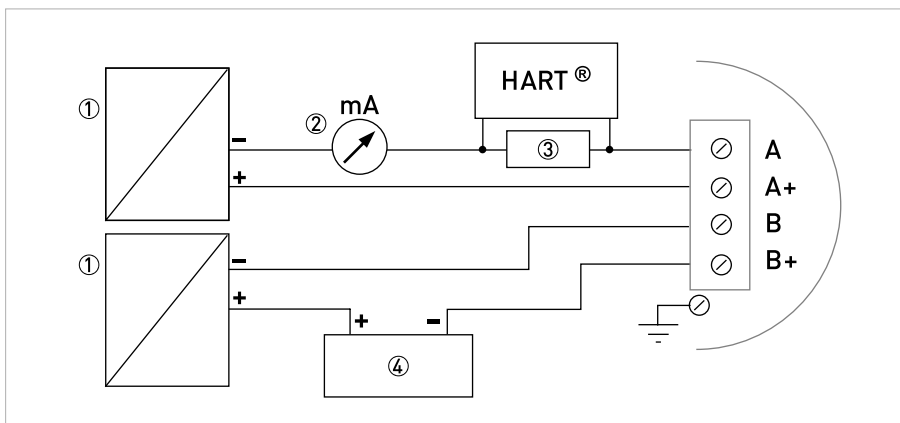

Figure 4-2: Electrical connection of current and pulse output

- ① Power supply per signal circuit
- ② Optional display unit
- ③ Load for HART®  $\geq 250 \Omega$
- ④ e.g. counter

The maximum load resistance is calculated as follows:

$$R_L = \frac{U_{ext.} - 14V}{22 mA}$$

### 4.3 Remote version connection

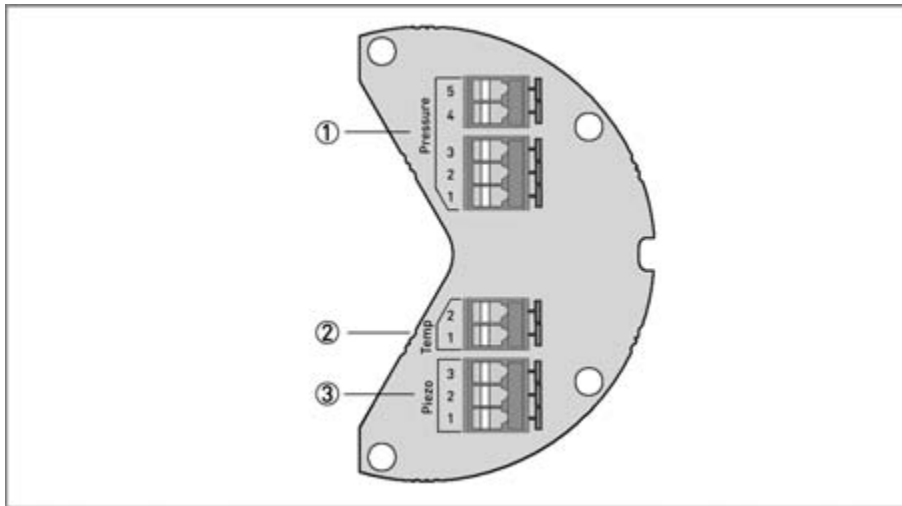

The connections in the sensor and wall mount bracket connection boxes are identical in construction.

#### Connection cable strand colour

	Connection	Terminal no.:	Strand colour
①	Pressure sensor	5	brown
		4	rose / pink
		3	green
		2	grey
		1	white
②	Temperature sensor	2	black
		1	purple
③	Vortex Sensor	3	red
		2	yellow
		1	blue

#### Remote connection cable



- ① Sensor connection side - strand length approx. 100mm
- ② Length of shrink hose approx. 30mm
- ③ Wall housing connection side - prefabricated shielding - length approx. 15mm

Please provide us with the missing information so that we can be of help to you as quickly as possible.

Then please fax this page to the appropriate sales associate. We will then contact you as soon as possible.

### Device data

Nominal connection size:			
Pressure rating:			
Raised face:			
Material of pipeline:			
Connection type:	<input type="checkbox"/> Flange	<input type="checkbox"/> Sandwich	
Design:	<input type="checkbox"/> Compact	<input type="checkbox"/> Remote 5 m cable length	<input type="checkbox"/> Remote 10 m cable length
Display:	<input type="checkbox"/> With	<input type="checkbox"/> Without	
Approval:	<input type="checkbox"/> No Ex	<input type="checkbox"/> ATEX II 2G Ex d ia [ia] IIC T6	<input type="checkbox"/> FM Class 1 Div. 1

### Rating data

Product:	
Operating pressure:	
Rated pressure:	
Operating temperature:	
Rated temperature:	
Operating density:	
Viscosity:	
Measuring range:	
Comments:	

### Contact data

Company:	
Contact person:	
Telephone number:	
Fax number:	
E-mail:	









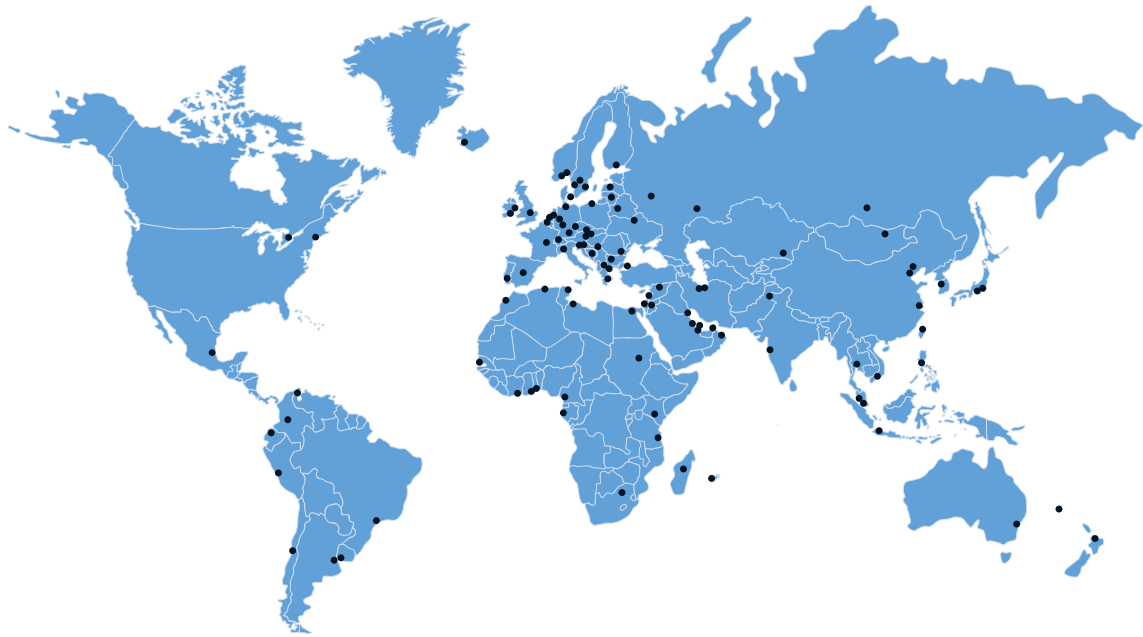

## KROHNE product overview

- Electromagnetic flowmeters
- Variable area flowmeters
- Ultrasonic flowmeters
- Mass flowmeters
- Vortex flowmeters
- Flow controllers
- Level meters
- Temperature meters
- Pressure meters
- Analysis products
- Measuring systems for the oil and gas industry
- Measuring systems for sea-going tankers

Head Office KROHNE Messtechnik GmbH  
Ludwig-Krohne-Str. 5  
D-47058 Duisburg (Germany)  
Tel.: +49 (0)203 301 0  
Fax: +49 (0)203 301 10389  
info@krohne.de

The current list of all KROHNE contacts and addresses can be found at:  
[www.krohne.com](http://www.krohne.com)

**KROHNE**